

Application Note

Characteristic Cable Impedance

Characteristic cable impedance (Z_0) is a very important measurement in determining a cable's transmission capability. Maximum power is transmitted when the source has the same impedance as the load. Therefore the cable (line) should have the same characteristic impedance as the transmission equipment. The Z_0 of the transmitting equipment drives the maximum signal into the line and in turn the Z_0 of receiving equipment determines the maximum signal out of the line. Ideally, $Z_{0\text{TRANSMITTER}} = Z_{0\text{LINE}} = Z_{0\text{RECEIVER}}$. When the characteristic impedances do not match, part of the signal is reflected back to the source degrading the transmission path.

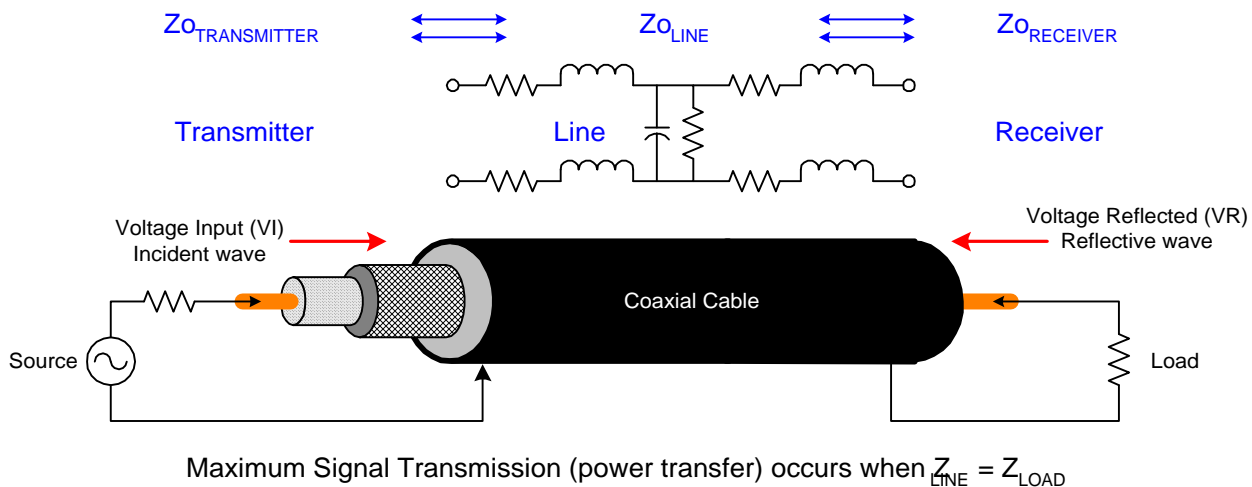

Figure 1: Maximum Signal Transmission

Although it can be represented in terms of inductors, capacitors and resistors, characteristic impedance is a complex number that is highly dependent on the frequency of the applied signal. Z_0 is not a function of the cable length. At high frequencies ($> 100\text{kHz}$), the characteristic impedance is almost purely resistive. At mid-range frequencies (1kHz), Z_0 is affected by capacitance (ωC) and at low frequencies ($\text{DC} - 100\text{Hz}$), Z_0 is influenced by conductance (G).

	Complex Equation		Resistive Measurement
	$Z_0 = \sqrt{\frac{R + j\omega L}{G + j\omega C}}$		$Z_0 = \sqrt{Z_{oc} Z_{sc}}$
frequency:	$f = \text{DC} - 100\text{Hz}$	$f = 1\text{kHz}$	$f = 100\text{kHz}$
Z_0 :	$Z_0 = \sqrt{\frac{R}{G}}$	$Z_0 = \sqrt{\frac{R}{\omega C}}$	$Z_0 = \sqrt{\frac{L}{C}}$

Figure 2: Characteristic Impedance Formulas

Application Note

Measuring Characteristic Cable Impedance

Yet, how does a cable manufacturer realistically measure the characteristic impedance of his product? In other words, what is the cable's Z_0 , the Z_{LINE} that must be equated to the transmitter and receiver? The characteristic impedance of coaxial cable can be determined from the formula:

$$Z_0 = \sqrt{Z_{OC} Z_{SC}}$$

Z_0 is the Characteristic Impedance
 Z_{OC} is the Open Circuit Impedance
 Z_{SC} is the Short Circuit Impedance

To measure a coaxial cable (in the frequency range 10 Hz to 2 MHz) on the IET Labs 7600 Plus.

1. Connect the cable via 7000-03 leads or fixture to the 7600 front panel output terminals.
2. Perform OPEN / SHORT zeroing on the 7000-03 leads (or your fixture).
3. Attach the cable to the 7000-03 leads (or your fixture) and measure Z_{OC} .
4. Short the cable ends and measure the Z_{SC} (cable short circuited).
5. Calculate Z_0 from the formula above.

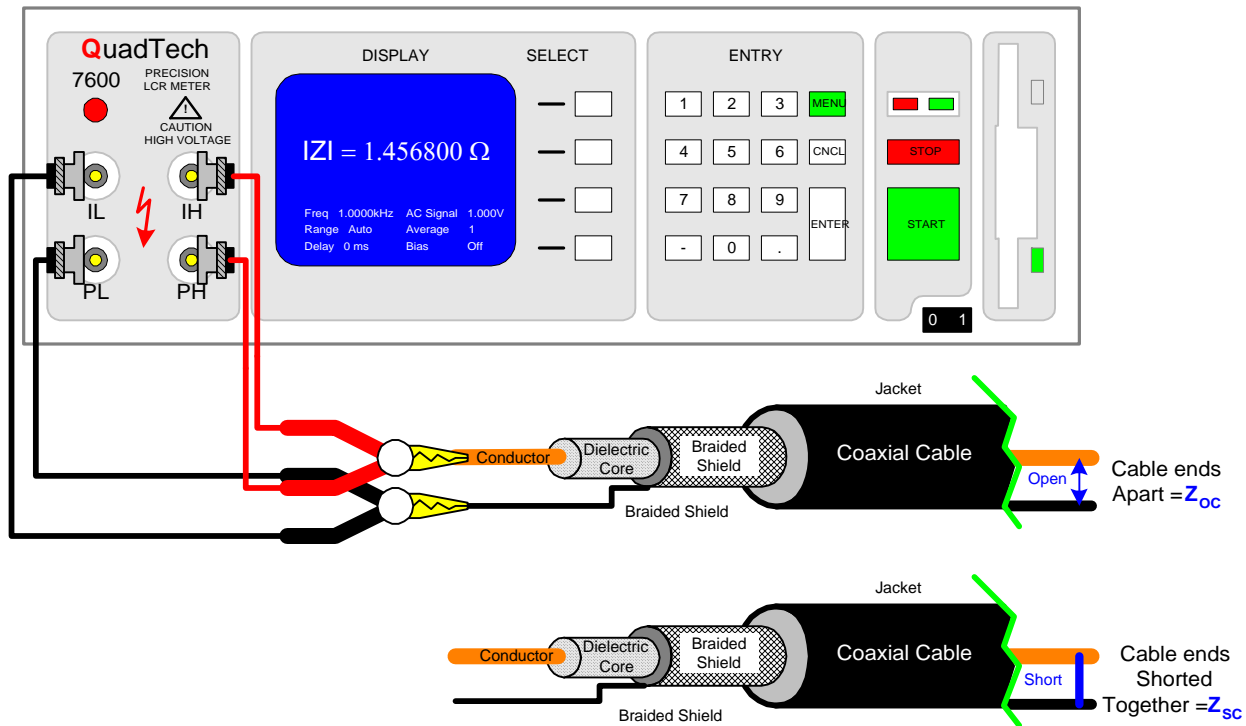

Figure 3: Coaxial Cable Impedance Measurement with 7000-03 Kelvin Leads

Z_{oc} is made with the cable ends apart by connecting the red Kelvin lead to the conductor and the black Kelvin lead to the braided shield. Similarly, Z_{sc} is made with the same connection, except the cable ends are shorted together.